



4e Verdieping



3e Verdieping



2e Verdieping

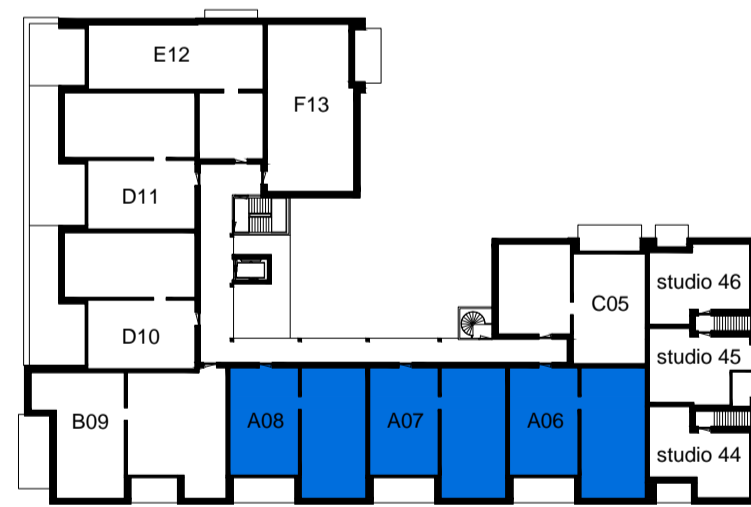

1e Verdieping

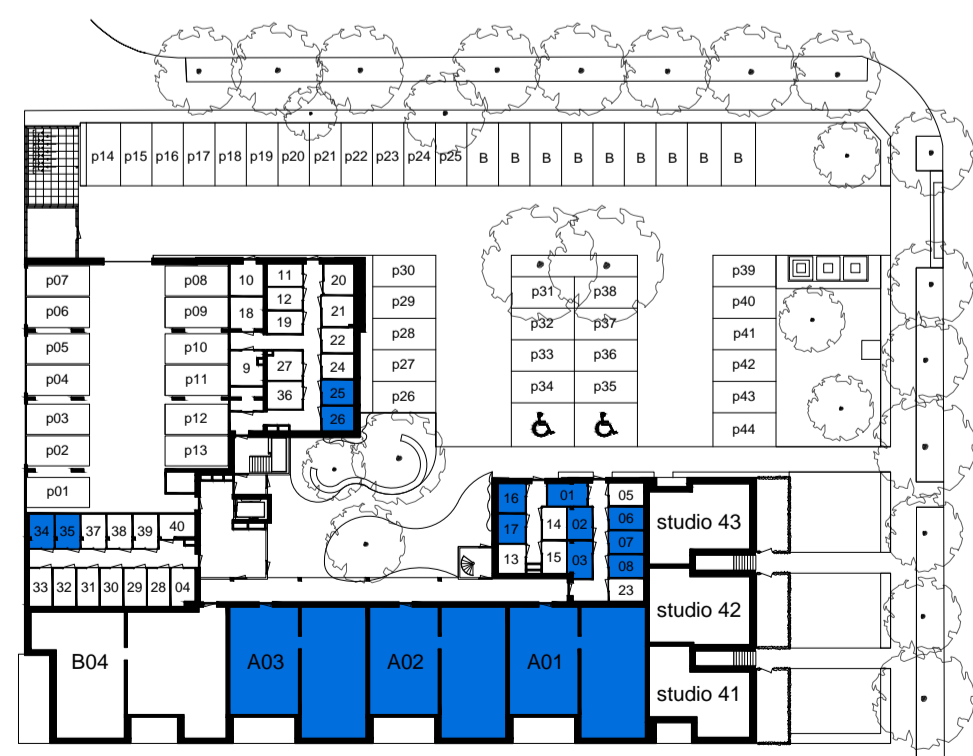

Begane grond

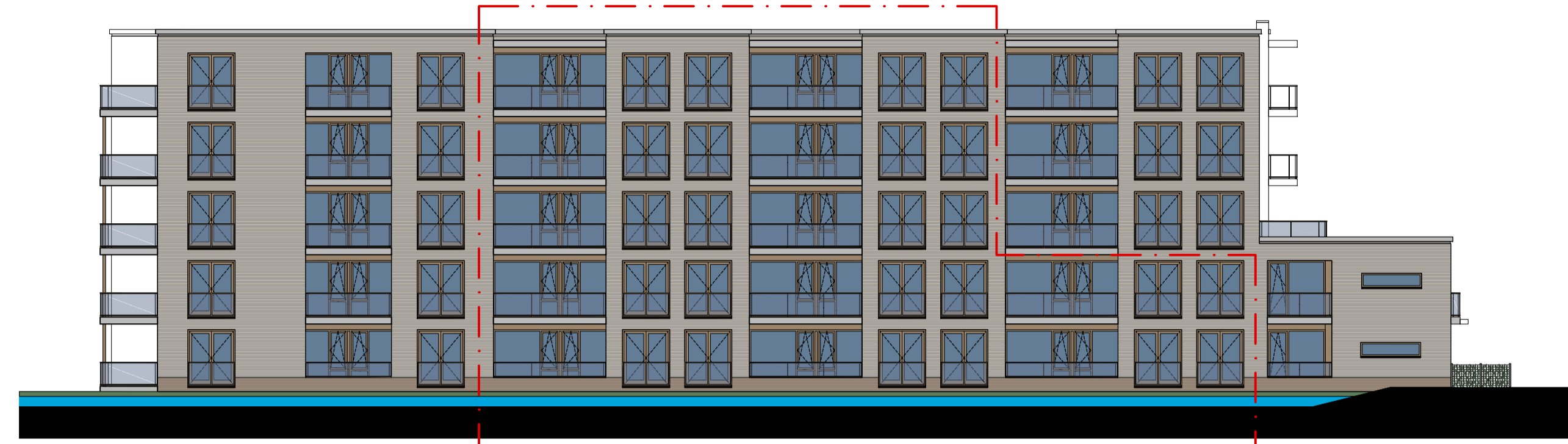

Zuidgevel

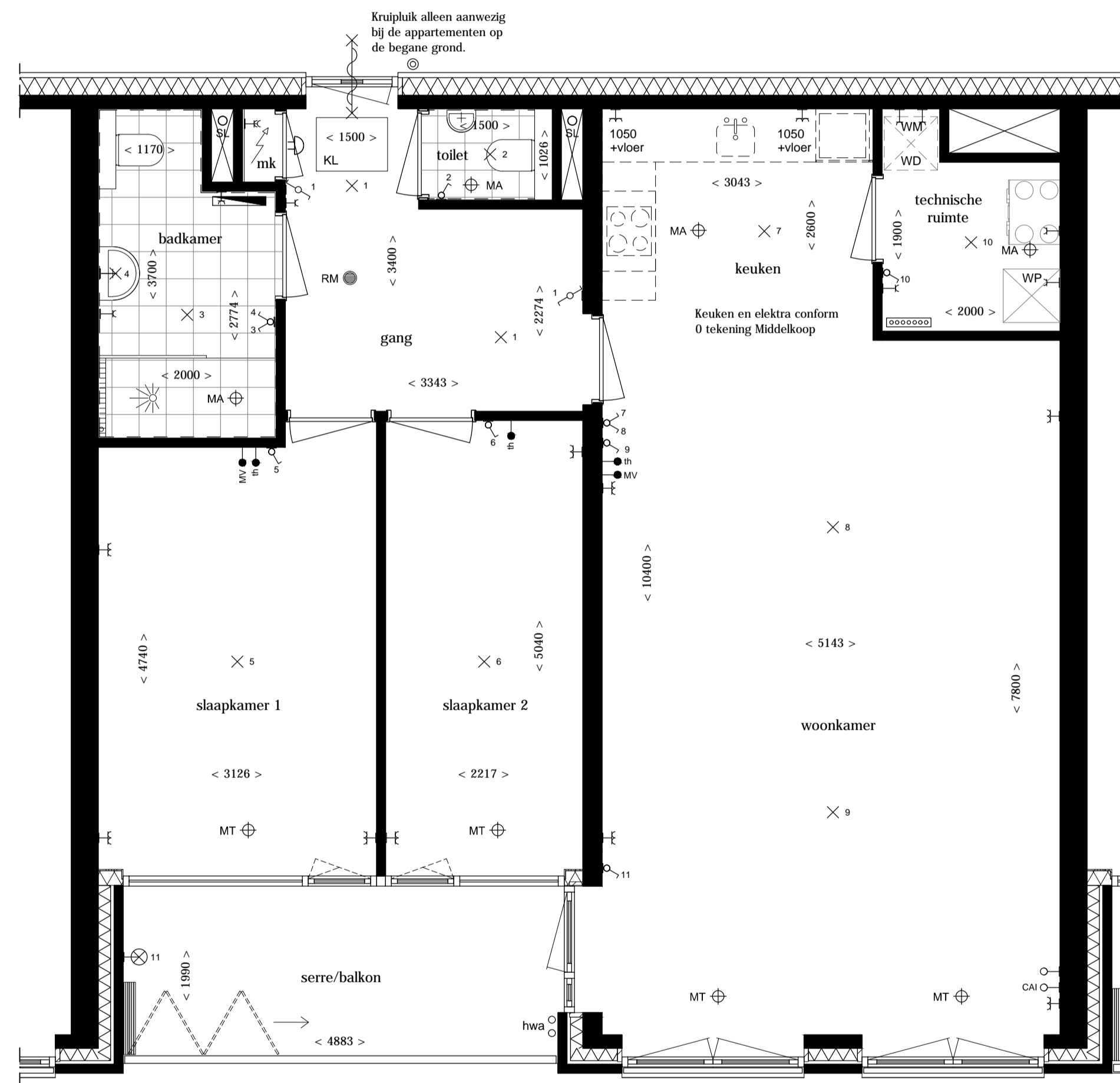

Appartement A06, A07, A08, A16, A17, A25, A26, A34, A35

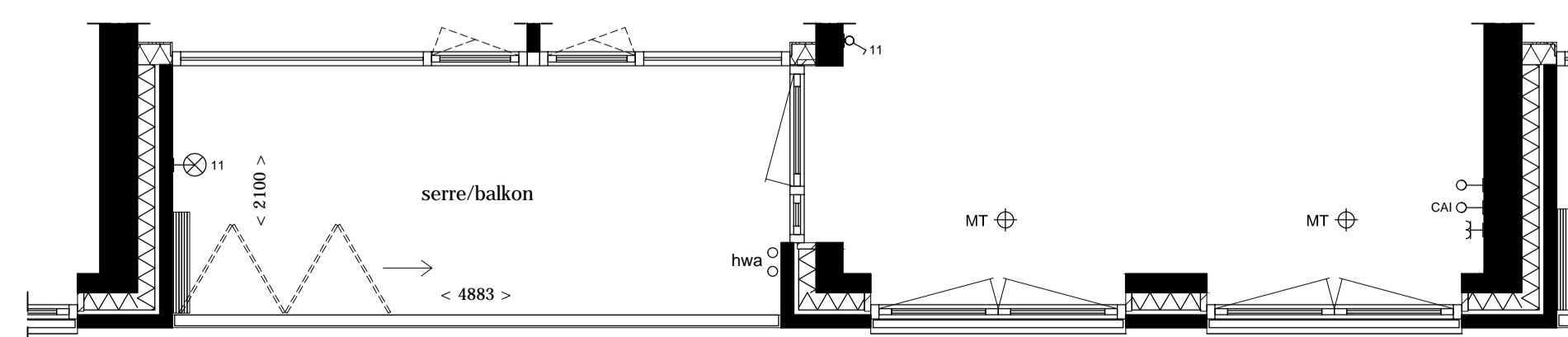

Appartement A01, A02, A03

RENVOOI

	Wand massief		Onbedrade aansluiting
	Isolatie		Onbedrade aansluiting centrale antenne aansluiting
	Beldrukker		Mechanische ventilatie, toevoer
	Bel schel		Mechanische ventilatie, afvoer
	Roekmelder		Mechanische ventilatie, afvoer
	Schakelaar		Zelfsluitende deur, WBOBO 30 minuten
	Serieschakelaar		Standleiding
	Wisselschakelaar		Electrische radiator
	Planfondaantaansluitpunt		Verdeler vloerverwarming
	Wandlantaansluitpunt		Opstelplaats WTW
	Planfondaantaansluitpunt		Opstelplaats warmtepomp
	Wandlantaansluitpunt		Opstelplaats wasmachine en wasdroger "condensdroger"
	Enkele wandcontactdoos gearad (1050+P tenzij anders vermeld)		Kruipruik
	Dubbele wandcontactdoos gearad (1050+P tenzij anders vermeld)		
	Dubbele wandcontactdoos gearad (300+P tenzij anders vermeld)		
	Aansluitpunt thermostaat		
	Bediening mechanische ventilatie		

Indeling badkamer is indicatief.
Indeling badkamer conform 0 tekening showroom.



Aan deze artist impressie kunnen geen rechten worden ontleend

Nieuwbouw van 40 appartementen en 6 studio's, Anna van Saksenweg te Vlaardingen

Bouwnr: Begane grond: A01, A02, A03 3e Verdieping: A25, A26
 1e Verdieping: A06, A07, A08 4e Verdieping: A34, A35
 2e Verdieping: A16, A17

Plattegronden: 1:50 Formaat: A1
 Gevels: 1:200 Datum: 10.09.2024
 Plattegronden overzicht: 1:600 Tekeningnummer: VK-01

Realisatie: Architect:



Willigen Partners
 VASTGOEDEXPLOITATIE

Ontwikkeling:

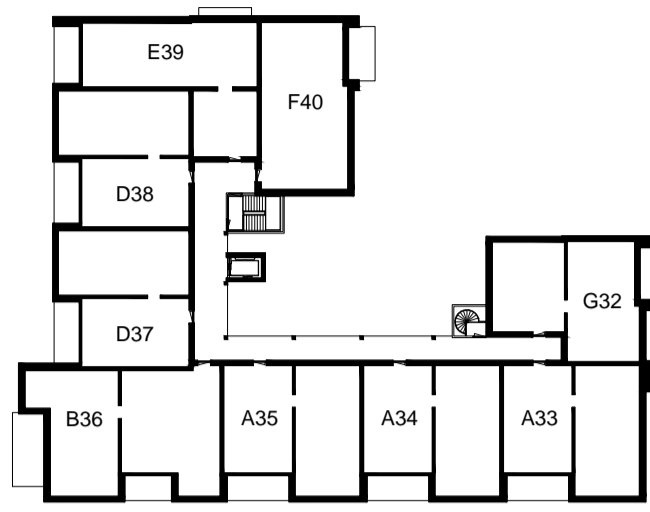

4e Verdieping



Zuidgevel



Oostgevel

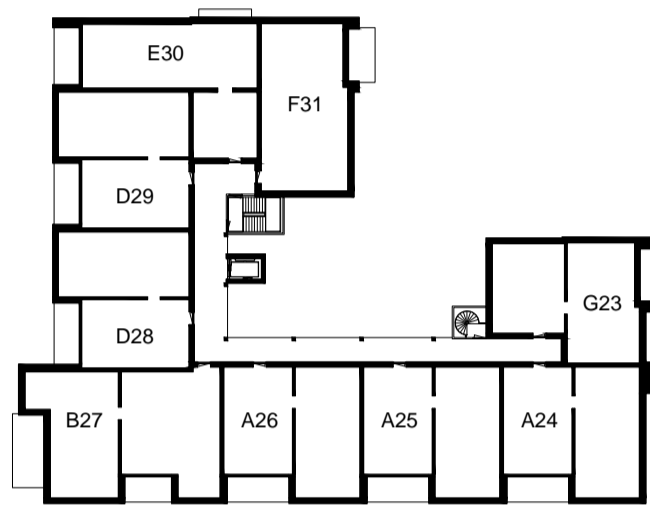

3e Verdieping



2e Verdieping

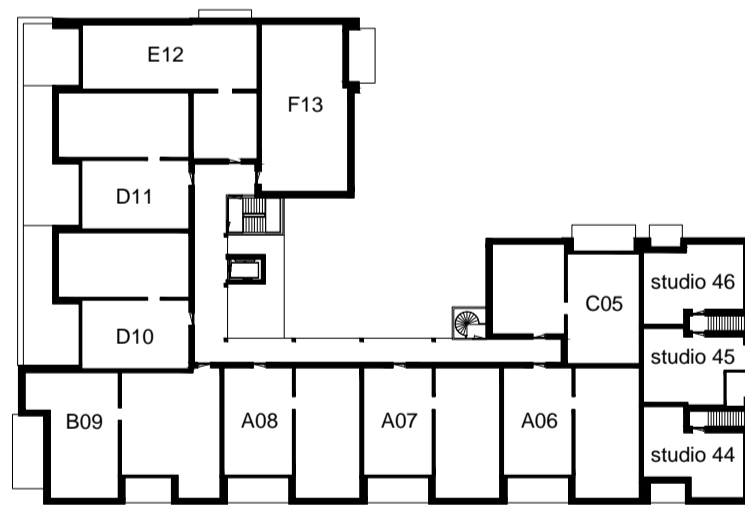

1e Verdieping

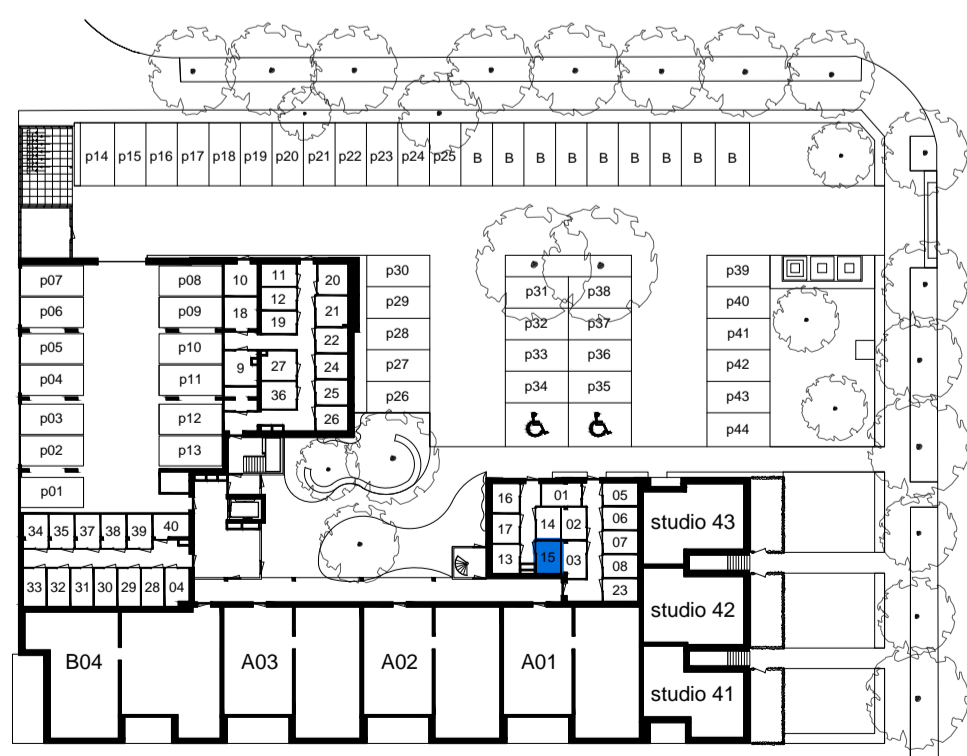

Begane grond

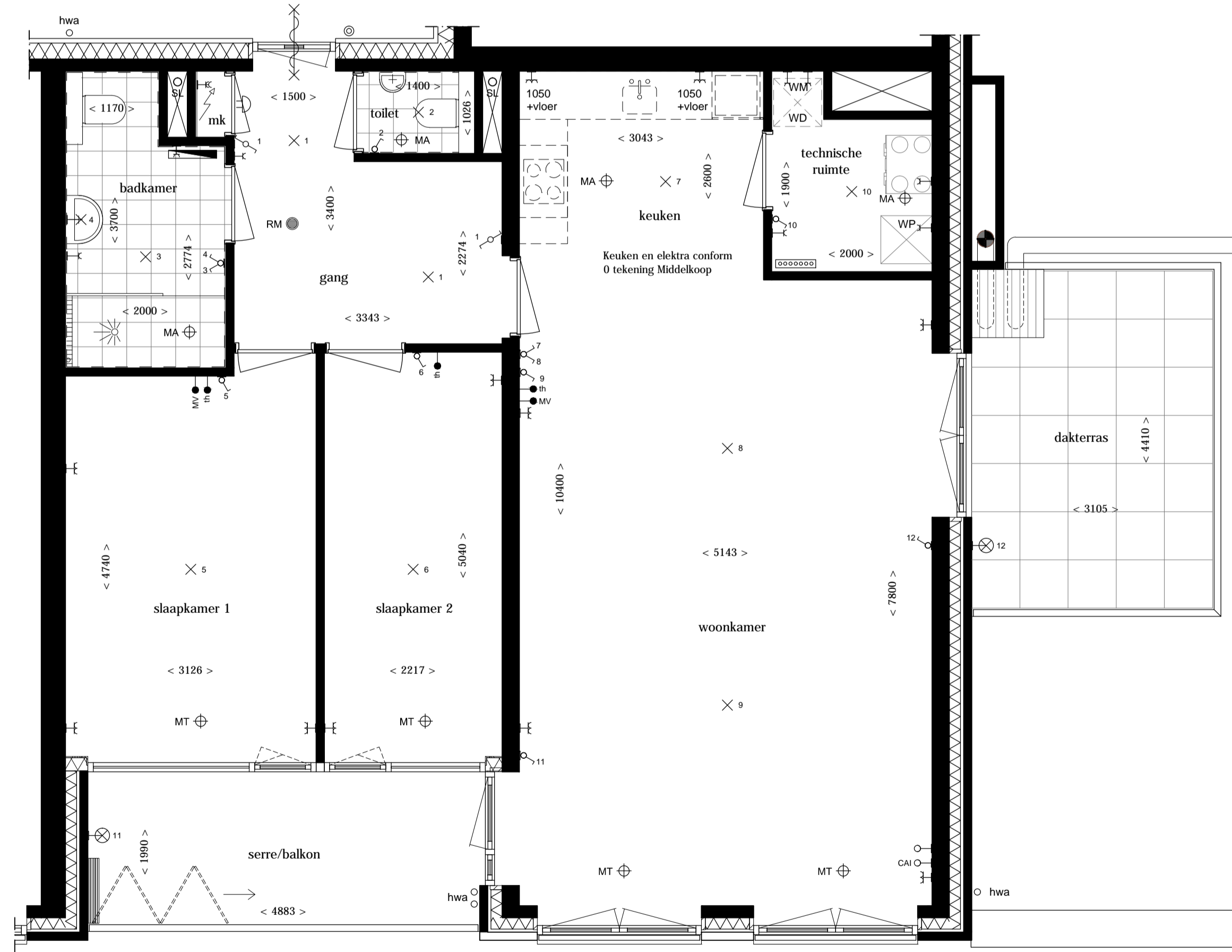

RENVOOI

	Wand massief		Onbedrade aansluiting
	Isolatie		Onbedrade aansluiting centrale antenne aansluiting
	Beldrukker		Mechanische ventilatie, toevoer
	Bel schel		Mechanische ventilatie, afvoer
	Roekmelder		Zelfsluitende deur, WBOBO 30 minuten
	Schakelaar		Standleiding
	Serieschakelaar		Electrische radiator
	Wisselschakelaar		Verdelers vloerverwarming
	Planfondichtaansluitpunt		Opstelplaats WTW
	Wandlichtaansluitpunt		Opstelplaats warmtepomp
	Planfondichtaansluitpunt		Opstelplaats wasmachine en wasdroger "condensdroger"
	Wandlichtaansluitpunt		Kruipruik
	Enkele wandcontactdoos gearad, opbouw (1050+P tenzij anders vermeld)		
	Dubbele wandcontactdoos gearad, opbouw (1050+P tenzij anders vermeld)		
	Dubbele wandcontactdoos gearad (300+P tenzij anders vermeld)		
	Aansluitpunt thermostaat		
	Bediening mechanische ventilatie		

Indeling badkamer is indicatief.
Indeling badkamer conform 0 tekening showroom.



Aan deze artist impressie kunnen geen rechten worden ontleend

Nieuwbouw van 40 appartementen en 6 studio's, Anna van Saksenweg te Vlaardingen

Bouwnr: 2e Verdieping: A15

Plattegronden: 1:50	Formaat: A1
Gevels: 1:200	Datum: 10.09.2024
Plattegronden overzicht: 1:600	Tekeningnummer: VK-02

Realisatie:  Architect: 



Ontwikkeling:

VASTGOEDEXPLOITATIE



4e Verdieping

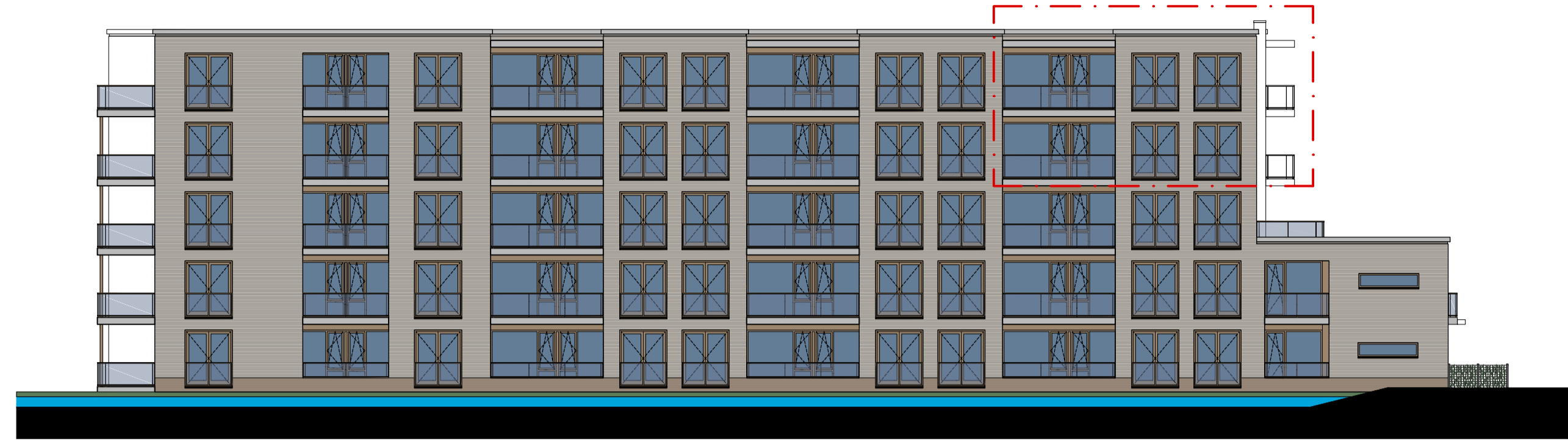

Zuidgevel



Oostgevel



3e Verdieping

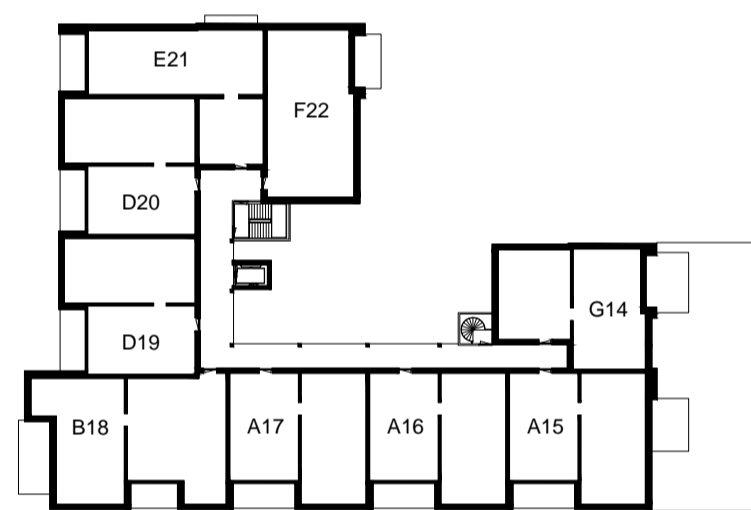

2e Verdieping

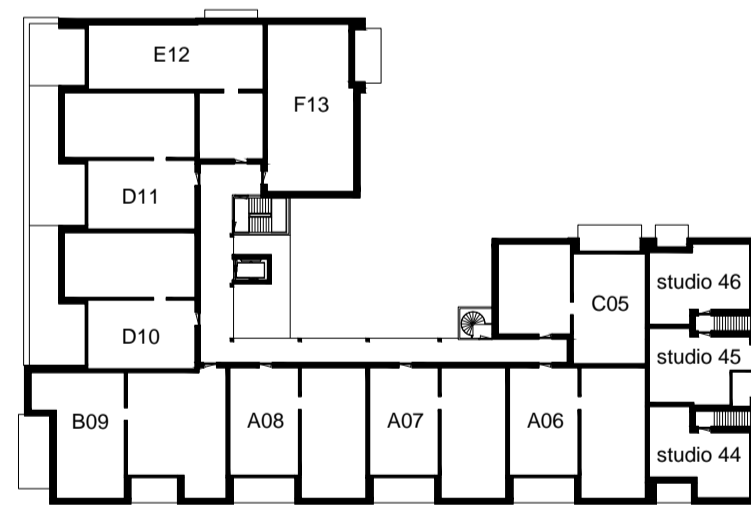





























1e Verdieping



Begane grond



RENVOOI

	Wand massief		Onbedrade aansluiting
	Isolatie		Onbedrade aansluiting centrale antenne aansluiting
	Beldrukker		Mechanische ventilatie, toevoer
	Bel schel		Mechanische ventilatie, afvoer
	Rookmelder		Zelfsluitende deur, WBOBO 30 minuten
	Schakelaar		Standleiding
	Serieschakelaar		Electrische radiator
	Wisselschakelaar		Verdelers vloerverwarming
	Plafondlichtaansluitpunt		Opstelplaats WTW
	Wandlichtaansluitpunt		Opstelplaats warmtepomp
	Plafondlichtaansluitpunt		Opstelplaats wasmachine en wasdroger "condensdroger"
	Wandlichtaansluitpunt		Kruipluik
	Enkele wandcontactdoos geaard (1050+P tenzij anders vermeld)		
	Dubbele wandcontactdoos geaard, opbouw (1050+P tenzij anders vermeld)		
	Dubbele wandcontactdoos geaard (300+P tenzij anders vermeld)		
	Aansluitpunt thermostaat		
	Bediening mechanische ventilatie		

Indeling badkamer is indicatief.
Indeling badkamer conform 0 tekening showroom.

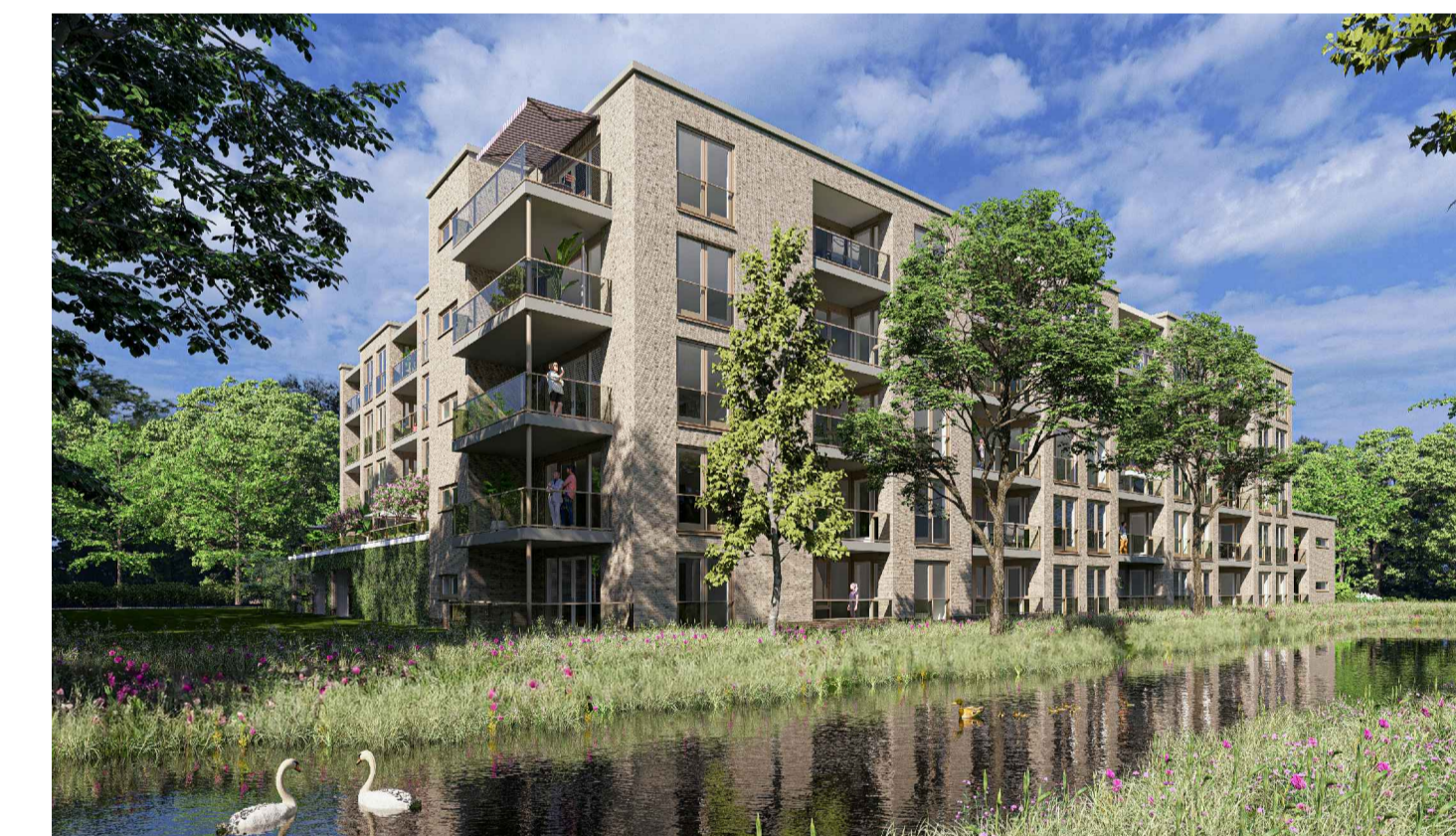

Aan deze artist impressie kunnen geen rechten worden ontleend

Nieuwbouw van 40 appartementen en 6 studio's, Anna van Saksenweg te Vlaardingen

Bouwnr: 3e Verdieping: A24
4e Verdieping: A33

Plattegronden: 1:50 Formaat: A1
Gevels: 1:200 Datum: 10.09.2024
Plattegronden overzicht: 1:600 Tekeningnummer: VK-03

Realisatie: Architect:



Ontwikkeling:

VASTGOEDEXPLOITATIE